

FUSELAGE - DESCRIPTION AND OPERATION

1. General

- A. This section describes the fuselage structure of the 208 and 208B airplanes in both the passenger and cargo configurations.

2. Description

NOTE: Refer to Figure 1 for a description of the major sections and fuselage station (FS) locations.

- A. The fuselage is of all- metal, semi-monocoque construction, with the skin carrying a portion of the structural load. The fuselage consists of the forward section, center section, tailcone section and stinger. Construction consists of formed bulkheads, longitudinal stringers, reinforcing channels and skins.
 - (1) The fuselage forward section consists of the instrument panel, pedestal, left sidewall circuit breaker panel, seat rails, floorboards, access plates and two avionic equipment racks. One is located behind the right side instrument panel and the other is located under the copilot's floorboard.
 - (2) The center section contains cargo/passenger compartment structures, floorboards, seat rails and access plates.
 - (3) The tail cone section contains the oxygen cylinder, oxygen filler valve access plate, flight control cables, emergency locator transmitter, baggage partition, access plates and stinger.
- B. On the 208 and 208 Cargomaster, the fuselage forward section is all the fuselage structure from FS 100.00 to FS 166.45; the center section is from FS 166.45 to FS 284.00; and the tail cone section is from FS 284.00 to FS 427.88.
- C. On the 208B, 208B Super Cargomaster and 208B Passenger airplanes, the fuselage forward section is all the fuselage structure from FS 100.00 to FS 166.45; the center section is from FS 166.45 to FS 332.00; and the tail cone section is from FS 332.00 to FS 475.88.

NOTE: Refer to Figure 2 for an illustration of fuselage main frames.

- D. The main frame of the airplane fuselage includes transverse frames (bulkheads), formers, longerons, stringers, carry-thru spars and frames around openings.
 - (1) The auxiliary structure consists of avionics equipment racks, floorboards, access plates and the pedestal.
 - (2) The avionic equipment rack is located in front of the copilot's seat, just forward of the door post.
- E. Attach fittings are provided on the fuselage for the horizontal stabilizer, wings, landing gear and seats. Carry-thru spars are provided through the fuselage for attachment of wings. Refer to appropriate chapters for a more complete description of how these attach fittings interface with the various components.

Figure 1 : Sheet 1 : Fuselage Sections

A22223

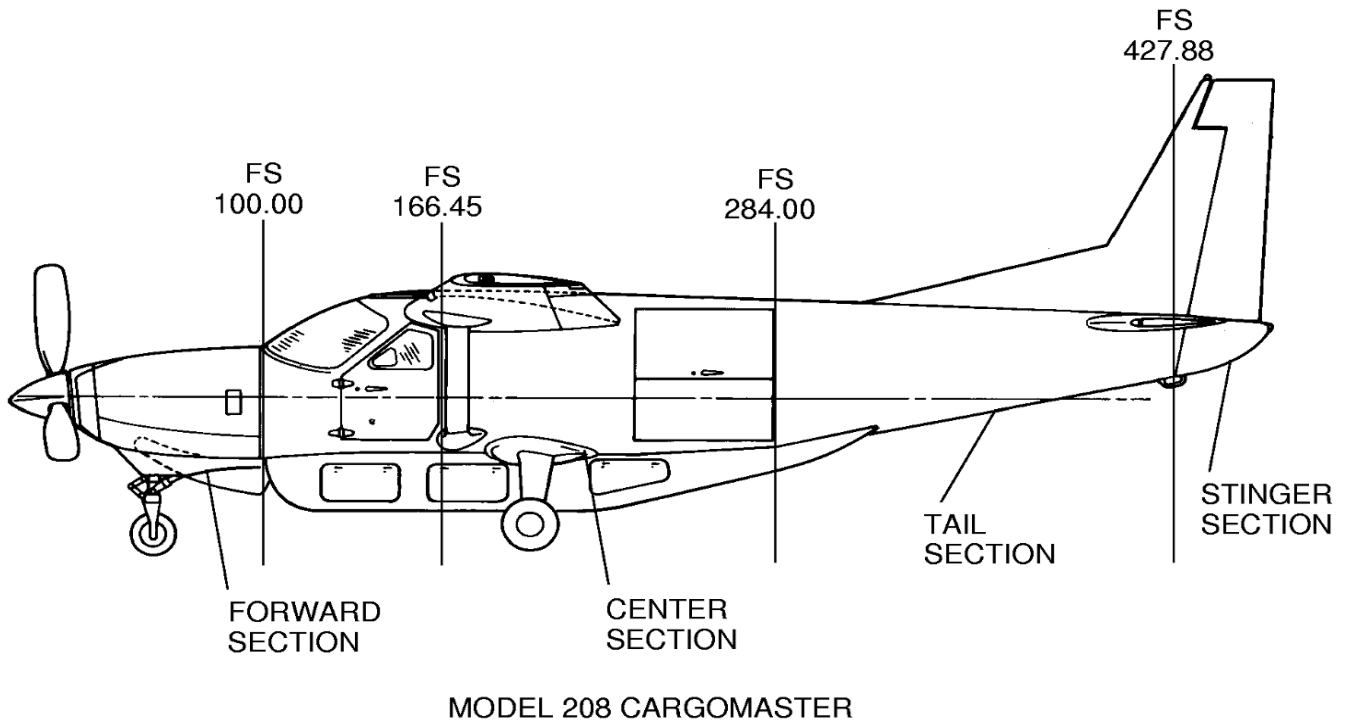
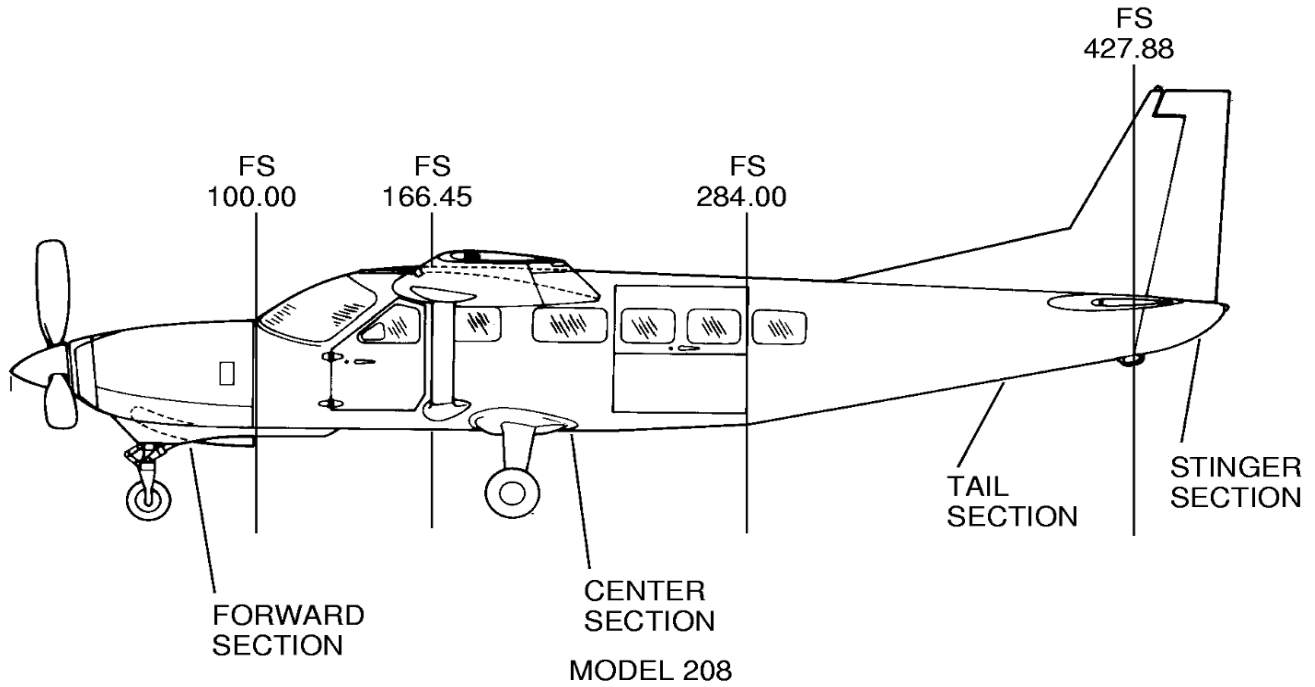

26103003
26102005

Figure 1 : Sheet 2 : Fuselage Sections

A22224

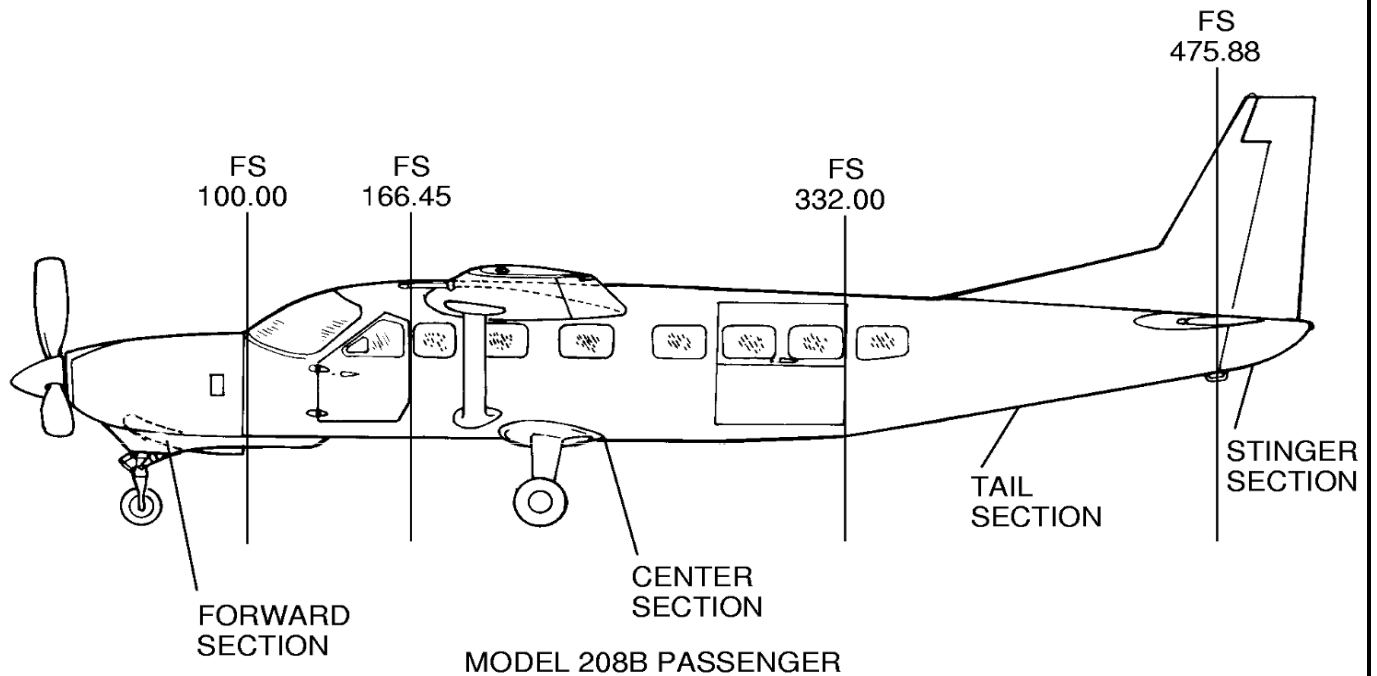
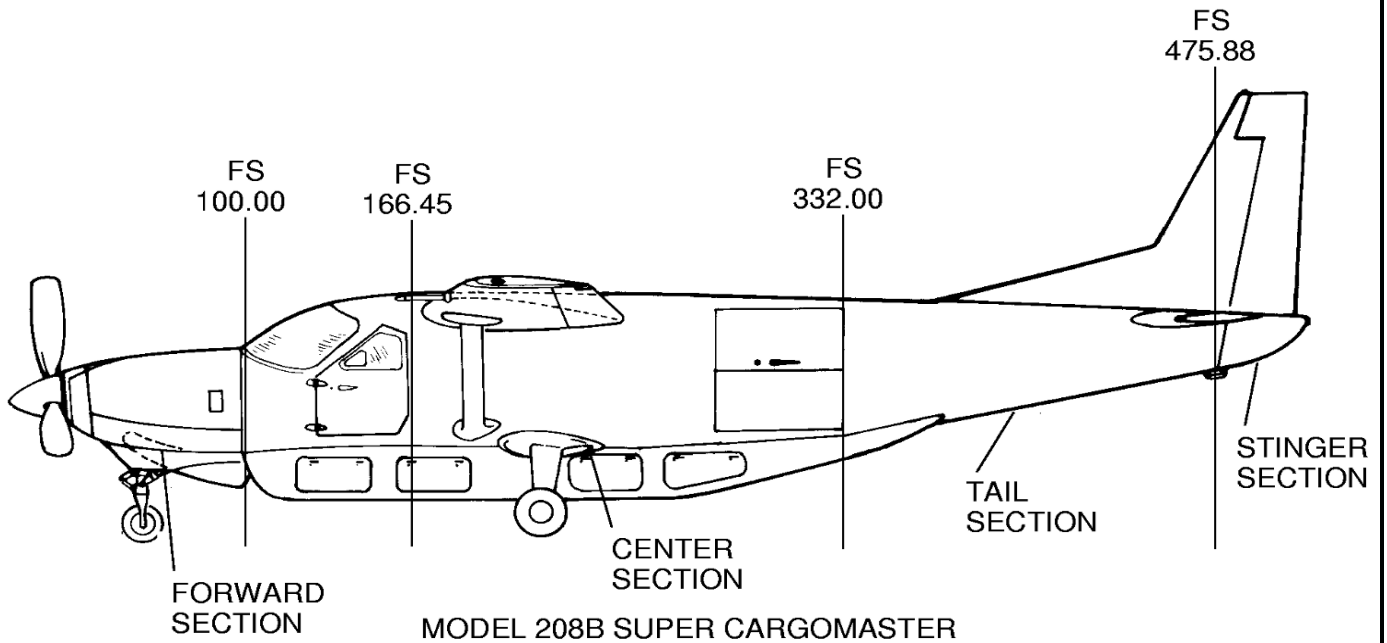

26101001
26103003

Figure 2 : Sheet 1 : Fuselage Main Frame

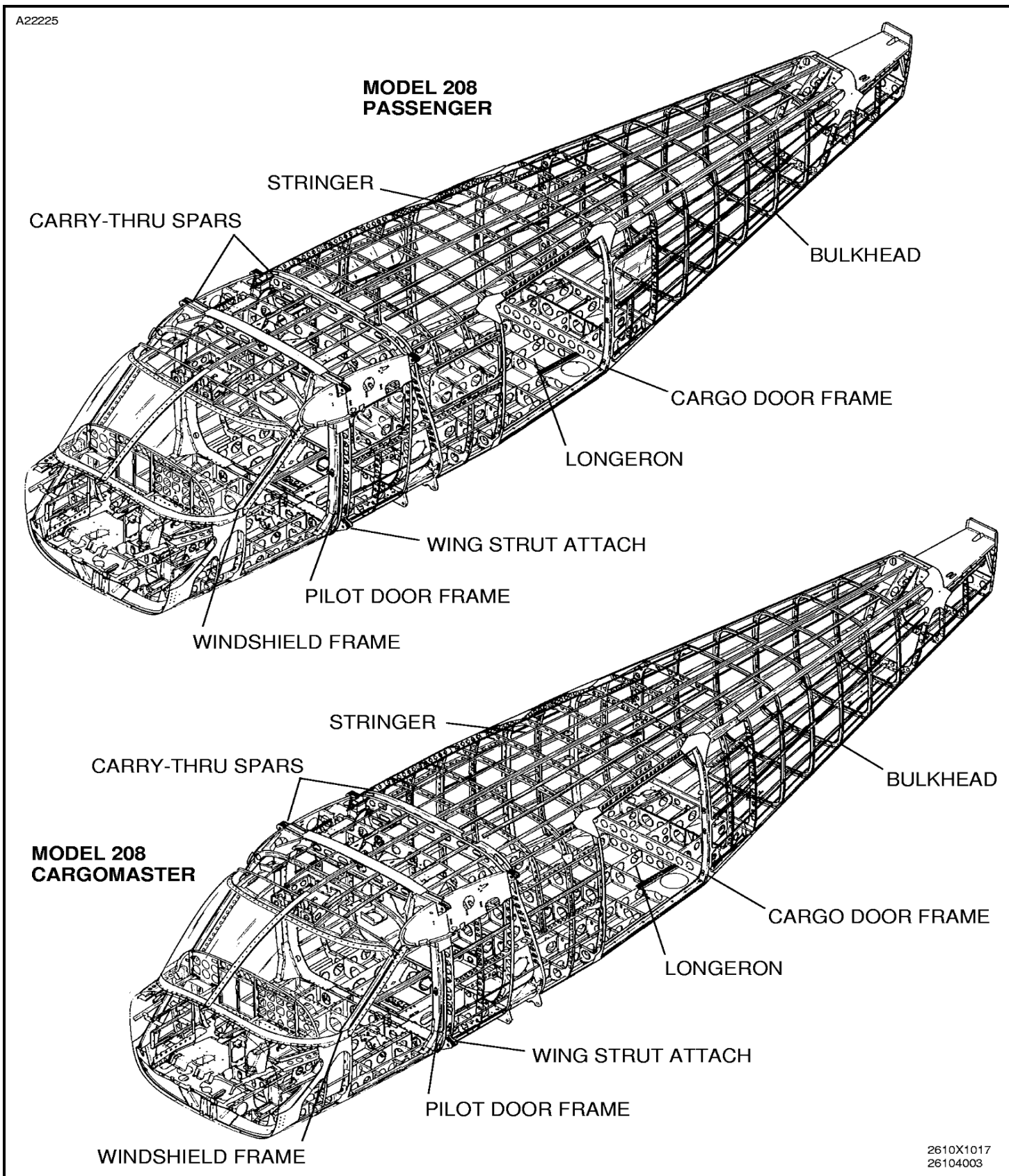

Figure 2 : Sheet 2 : Fuselage Main Frame

